

CORFLEX



G502 SERIES

Acoustic glass movable partitions with slim frames
Paired panels

FEATURES

- Anodized aluminum framing
- Top supported system
- No floor track
- Preparation for card reader (optional with hinged door)
- Horizontal mullions
- Optional panic bar
- Possibility of replacing glass with other materials
- Panel thickness: 51mm
- No visible screw

PROPERTIES

6MM GLASS

MAXIMUM HEIGHT PER PANEL

3048mm (10') with mullions

MAXIMUM WIDTH PER PANEL

1219mm (4')

SYSTEM WEIGHT

17,1 kg/m² (3,5 lbs/ft²)

GLASS TYPE

Tempered glass

TOP AND BOTTOM SEALS

Flexible sound seals

12MM GLASS

MAXIMUM HEIGHT PER PANEL

3048mm (10') with mullions

MAXIMUM WIDTH PER PANEL

1219mm (4')

SYSTEM WEIGHT

30,4 kg/m² (6,2 lbs/ft²)

GLASS TYPE

Tempered or laminated glass

TOP AND BOTTOM SEALS

Flexible sound seals

ACOUSTICAL PERFORMANCE

38 STC

VERTICAL SECTIONS

6MM GLASS

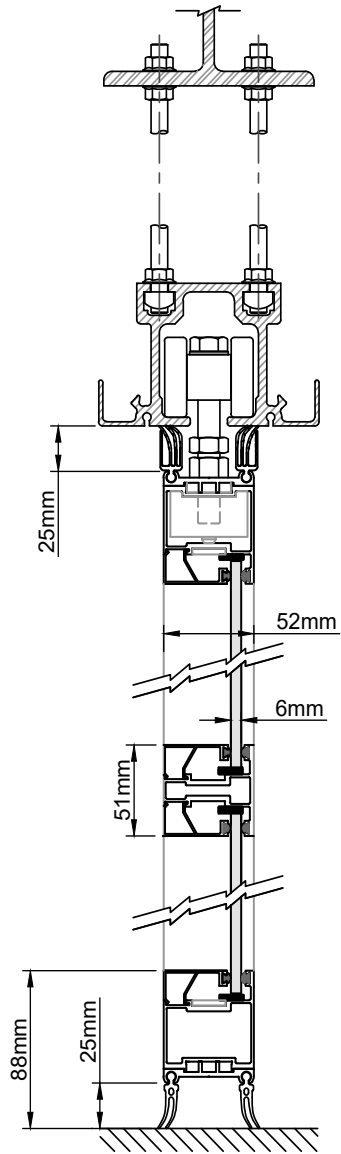

12MM GLASS

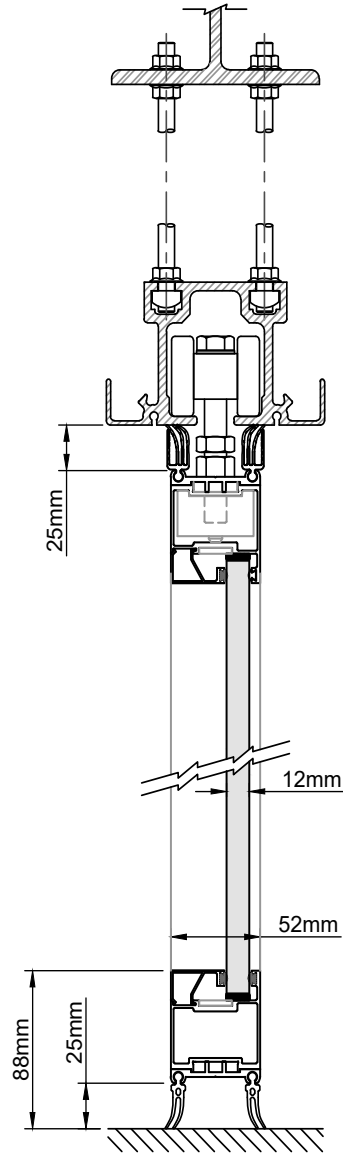

ELEVATION

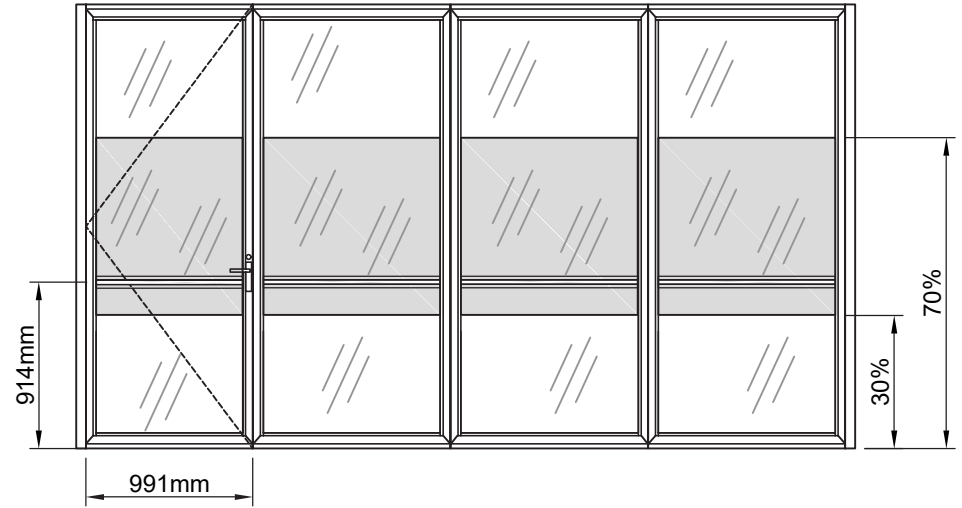

HINGED DOOR

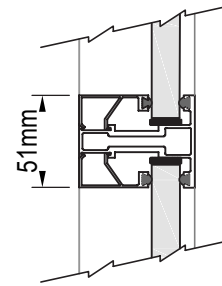

HORIZONTAL MULLION

STANDARD CONFIGURATION

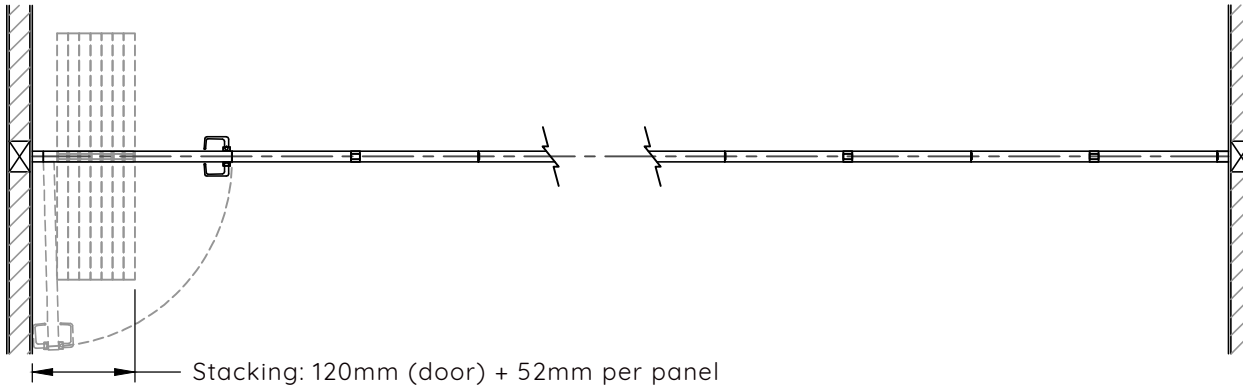

HORIZONTAL SECTION

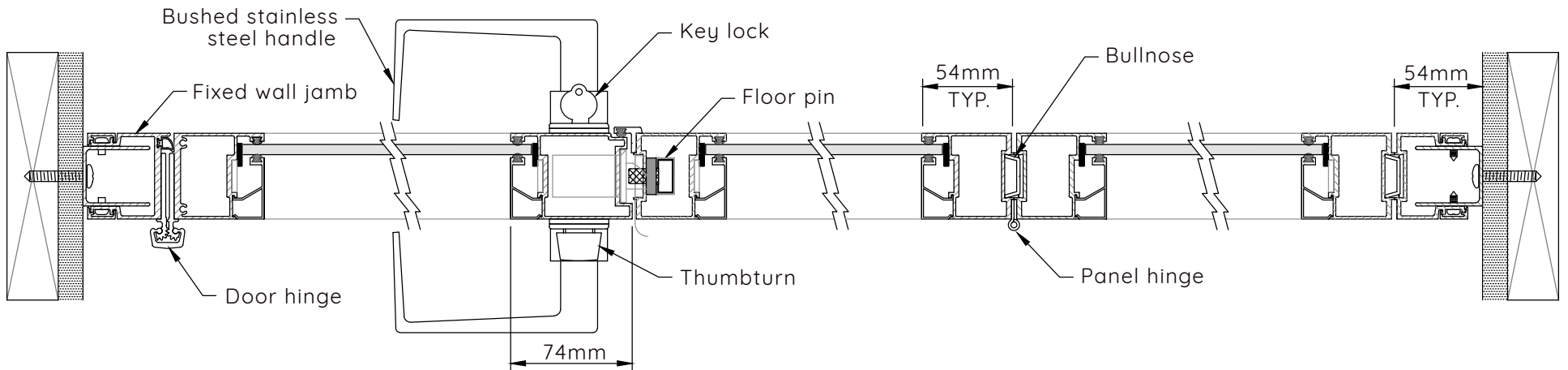

TRACK AND CARRIER

MAX. WEIGHT PER PANEL

205 kg (450 lbs)

* wheel carriers #40

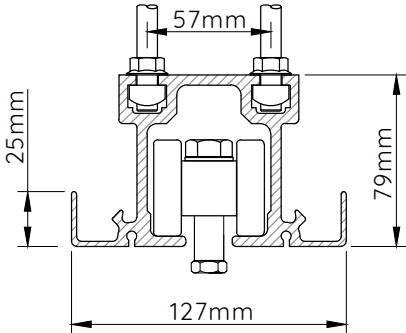

TRACK #40

TRACK SUSPENSIONS

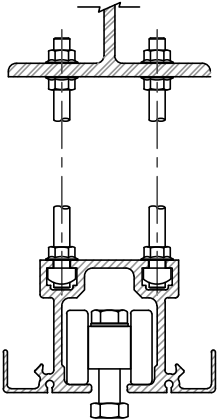

STEEL BEAM

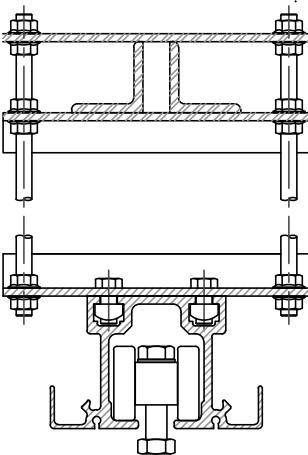

JOIST

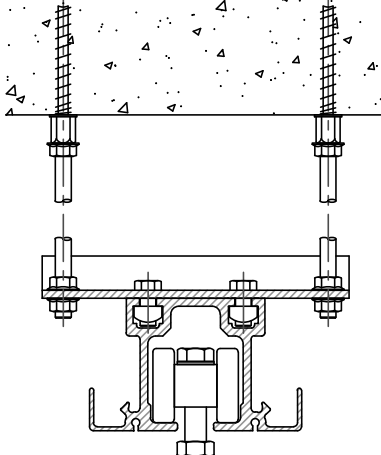

CONCRETE ANCHORING