

CORFLEX



G602 SERIES

Frameless glass wall
Paired panels

FEATURES

- Anodized aluminum shoes
- Top supported system
- No floor track
- No vertical trims
- Floor pin on all panels
- Choice of 2 profiles
- Optional panic bar (with pivot door)
- Optional automatic door closet (with pivot door)
- Optional stainless steel shoe cover

PROPERTIES

MAXIMUM HEIGHT PER PANEL

3658mm (12')

MAXIMUM WIDTH PER PANEL

1219mm (4')

SYSTEM WEIGHT

31,7 kg/m² (6,5 lbs/ft²)

TYPE OF GLASS

Tempered glass 12mm

TOP AND BOTTOM SWEEPS

Brushes

VERTICAL SECTION

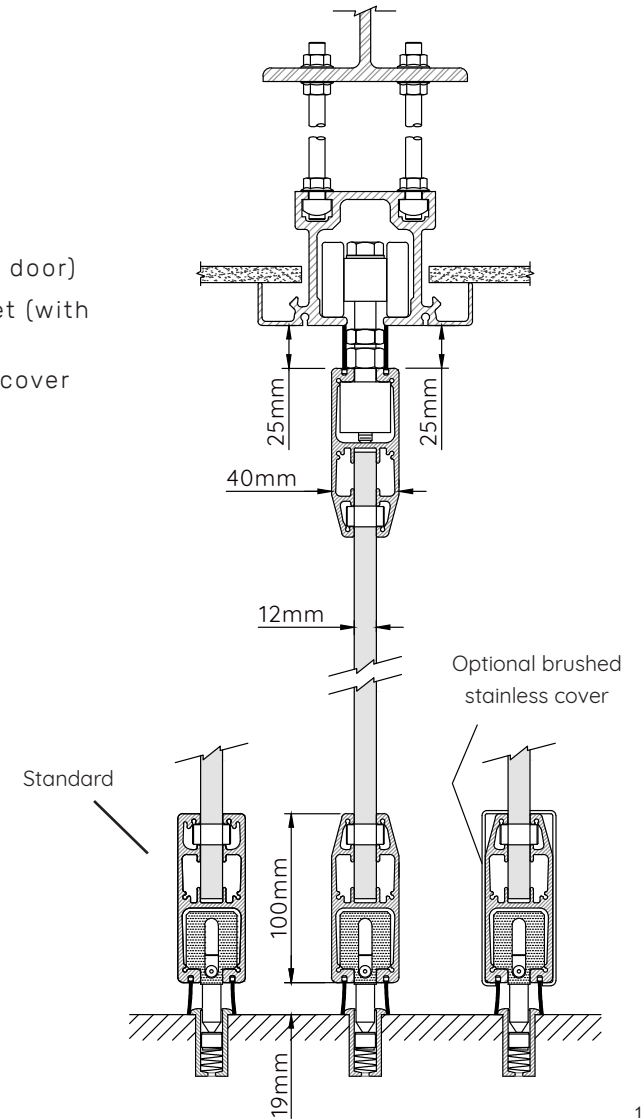

ELEVATIONS

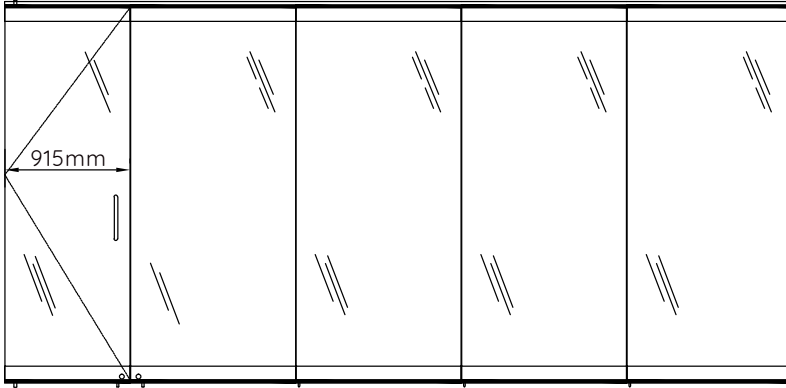

HINGED DOOR

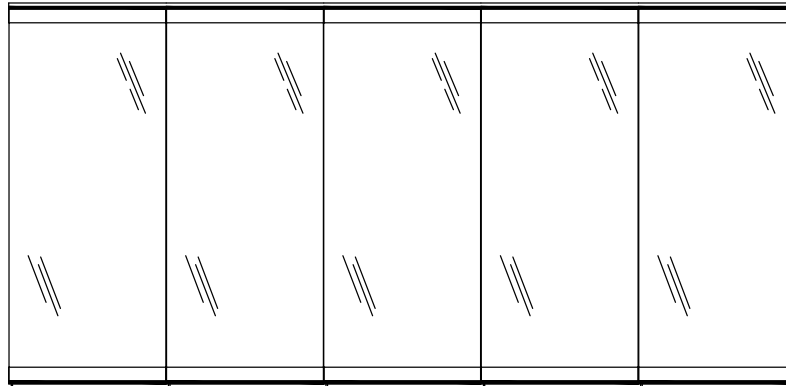

WITHOUT DOOR

STANDARD CONFIGURATIONS

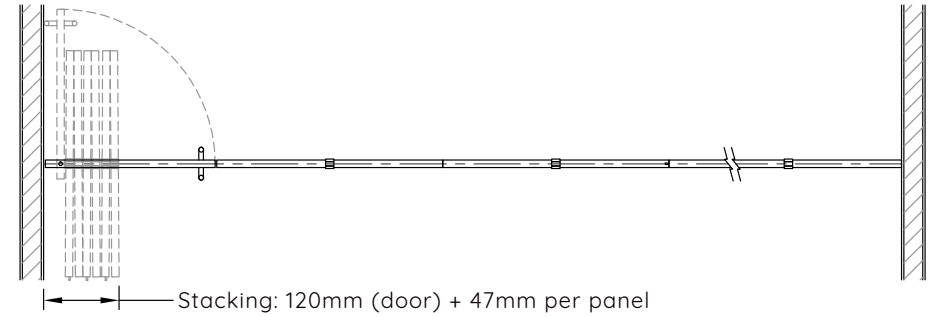

HINGED DOOR

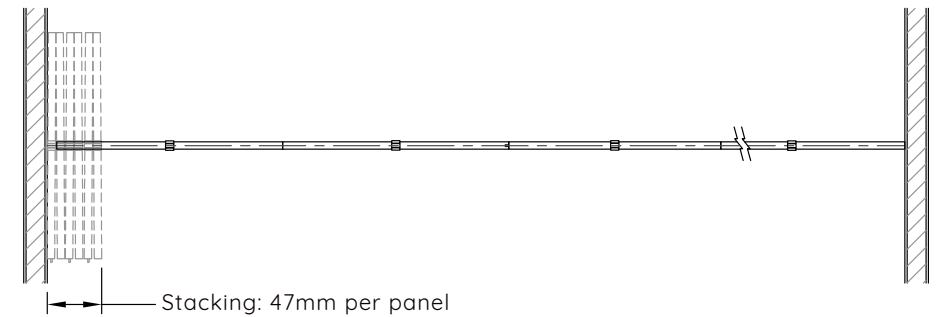

WITHOUT DOOR

HORIZONTAL SECTIONS

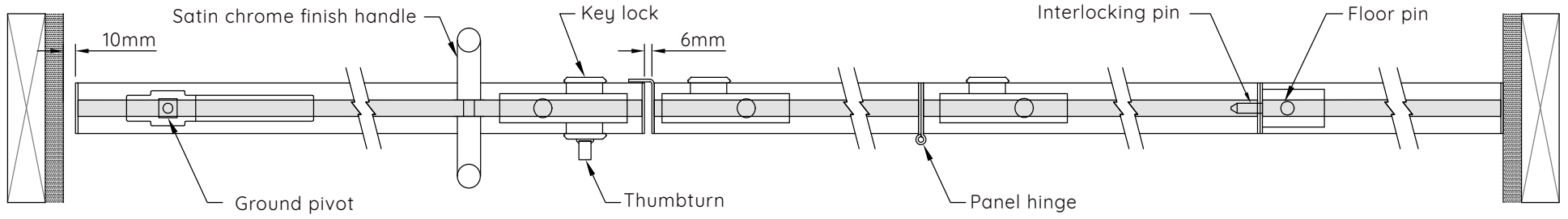

HINGED DOOR

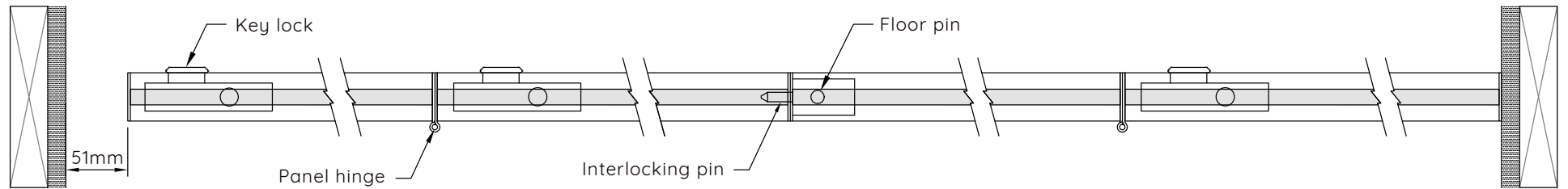

WITHOUT DOOR

TRACK AND CARRIER

MAX. WEIGHT PER PANEL

205 kg (450 lbs)

*2 wheels carrier # 40

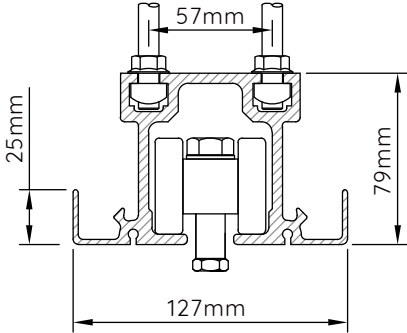

TRACK #40

TRACK SUSPENSIONS

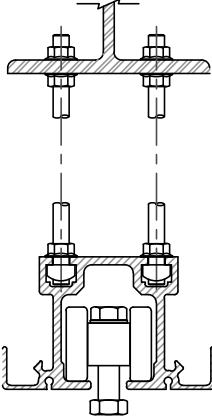

STEEL BEAM

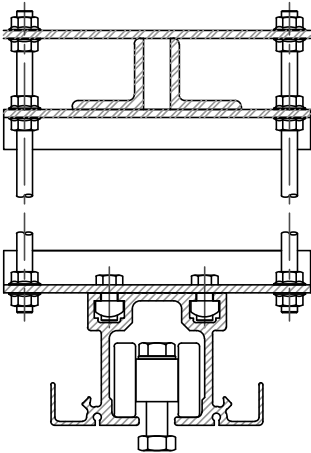

JOIST

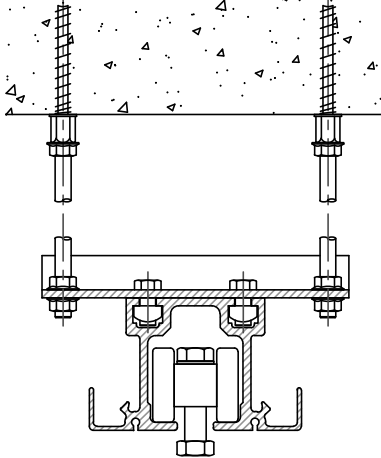

CONCRETE ANCHORING