

CORFLEX



G702 SERIES

High acoustic performance glass movable partitions
Paired panels

FEATURES

- Anodized aluminum framing
- Top supported system
- No floor tracks
- Optional 12mm tempered glass
- Optional switchable opacity glass (with 51mm double glazed units)
- Optional horizontal mullions
- Optional retractable bottom seals
- Optional panic bar
- Other optional substrates and finishes
- Preparation for optional card reader (with hinged door)
- No visible screws

PROPERTIES

38MM GLASS

MAXIMUM HEIGHT PER PANEL

3658mm (12')

MAXIMUM WIDTH PER PANEL

1219mm (4')

SYSTEM WEIGHT

44,01kg/m² (9lbs/ft²)

TYPE OF GLASS

Sealed double glazed unit

TOP AND BOTTOM SEALS

Flexible sound seals

ACOUSTICAL PERFORMANCE

44 STC

51MM GLASS*

MAXIMUM HEIGHT PER PANEL

3658mm (12')

MAXIMUM WIDTH PER PANEL

1219mm (4')

SYSTEM WEIGHT

48,9kg/m² (10lbs/ft²)

TYPE OF GLASS

Sealed double glazed unit

TOP AND BOTTOM SEALS

Flexible sound seals

ACOUSTICAL PERFORMANCE

44 STC

*This option is preferred for design purposes

VERTICAL SECTIONS

38MM GLASS

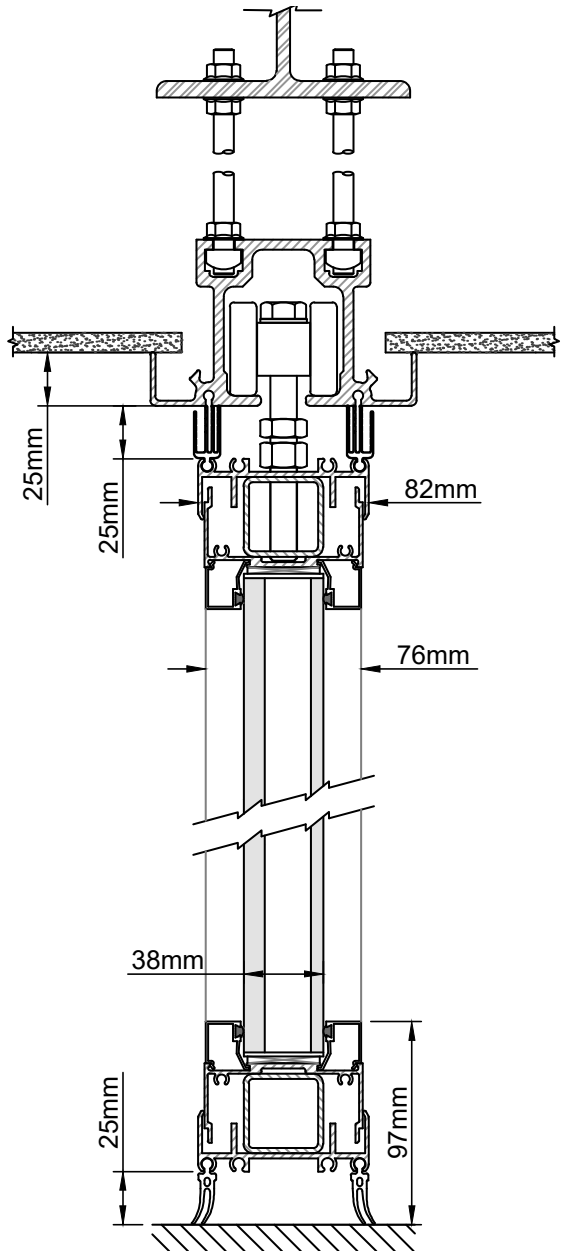

51MM GLASS

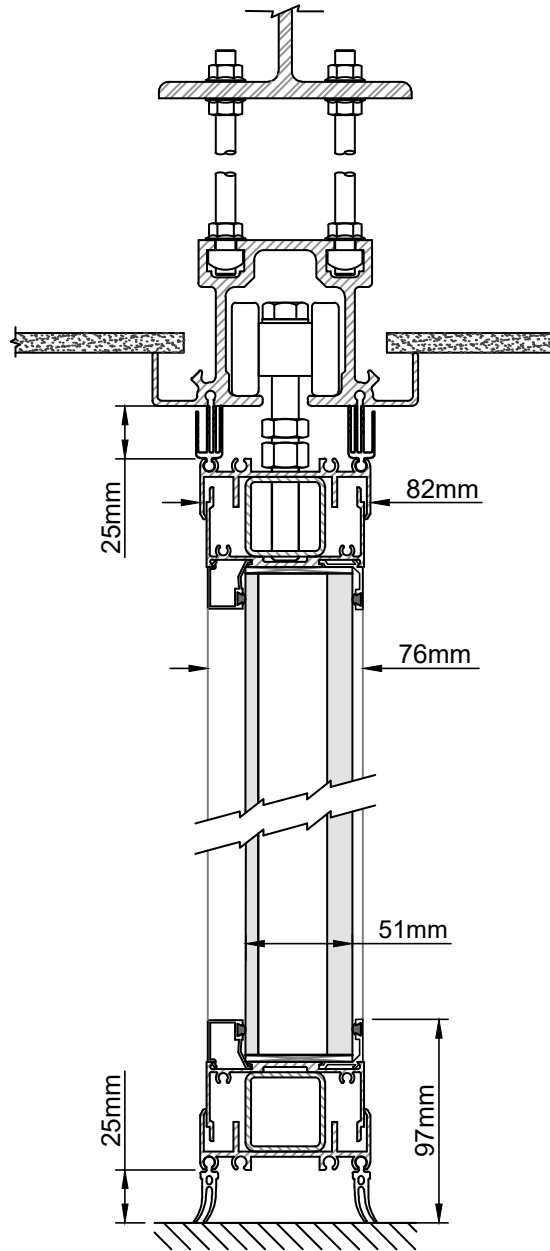

OPTIONS

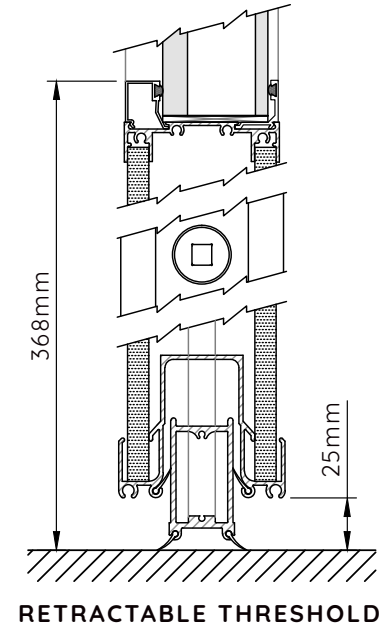

RETRACTABLE THRESHOLD

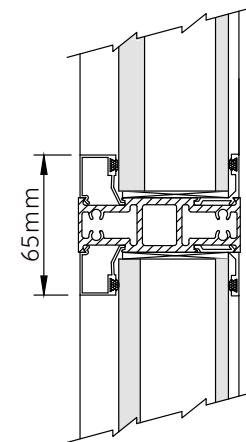

HORIZONTAL MULLION

ELEVATIONS

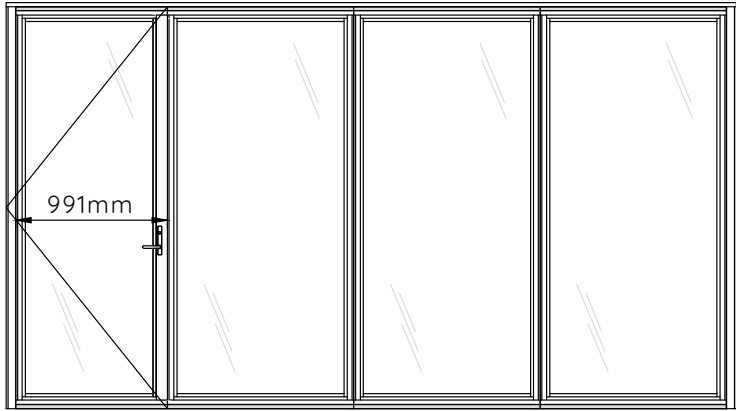

HINGED DOOR

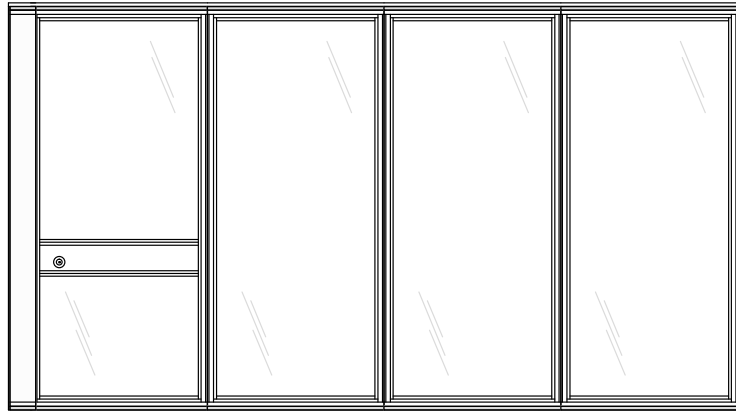

TELESCOPIC PANEL

STANDARD CONFIGURATIONS

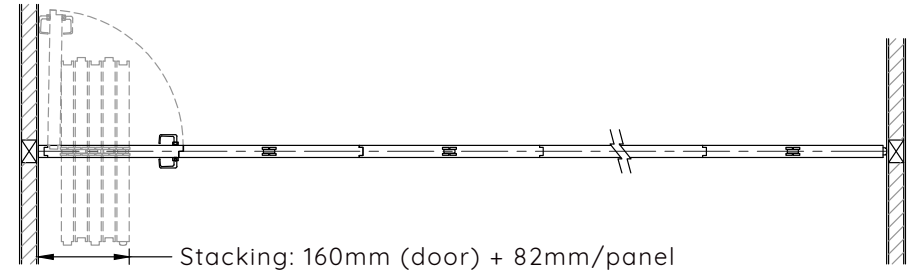

HINGED DOOR

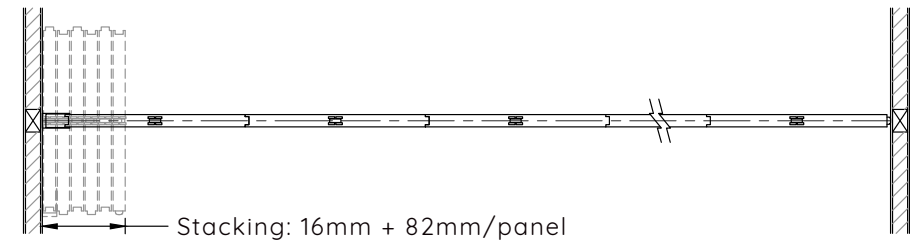

TELESCOPIC PANEL

HORIZONTAL SECTIONS

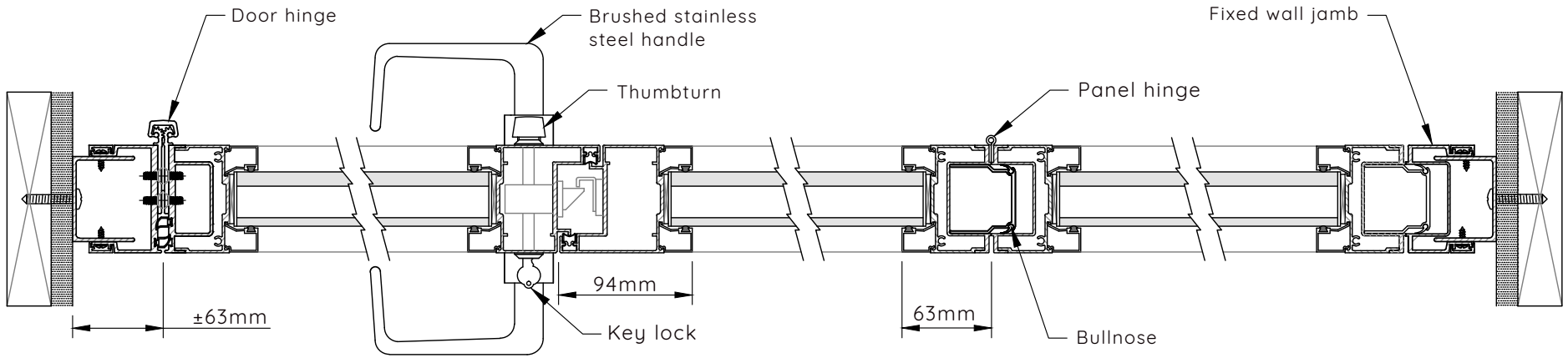

HINGED DOOR

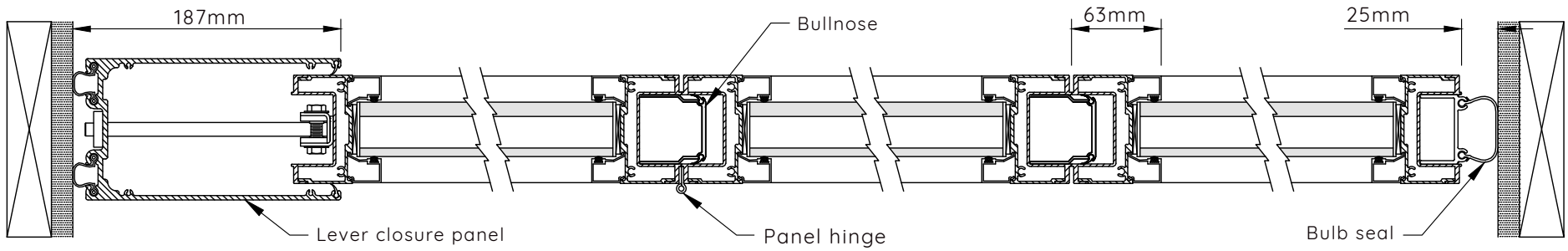

TELESCOPIC PANEL

TRACK AND CARRIERS

MAX. WEIGHT PER PANEL

410 kg (900lbs)

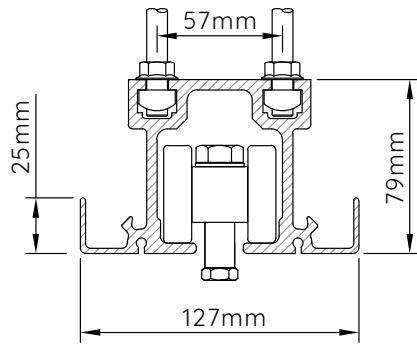

TRACK #40

TRACK SUSPENSIONS

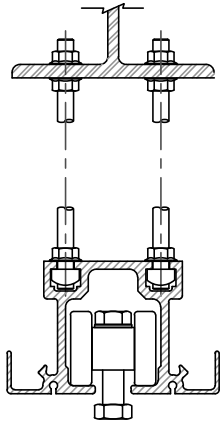

STEEL BEAM

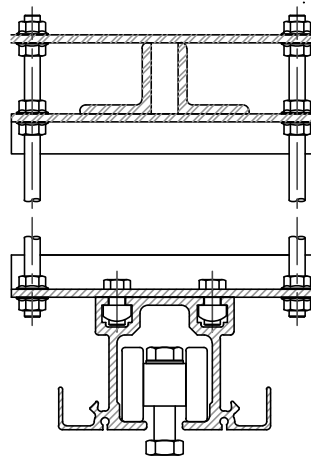

JOIST

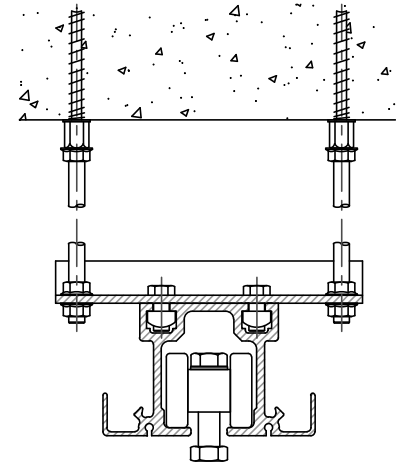

CONCRETE ANCHORING